

Wymiary (mm)

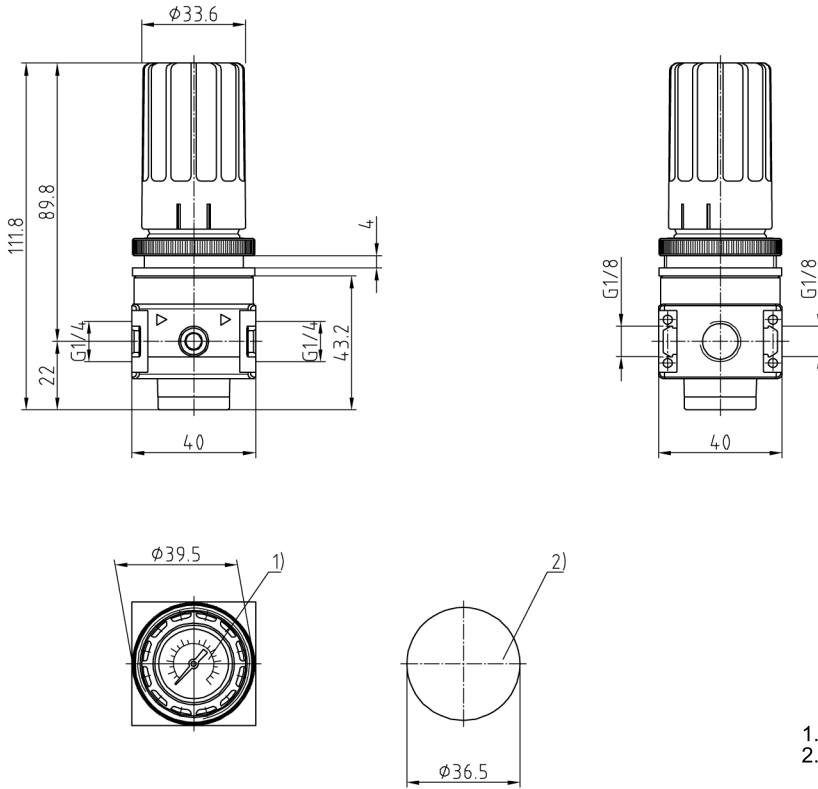

Przepływy

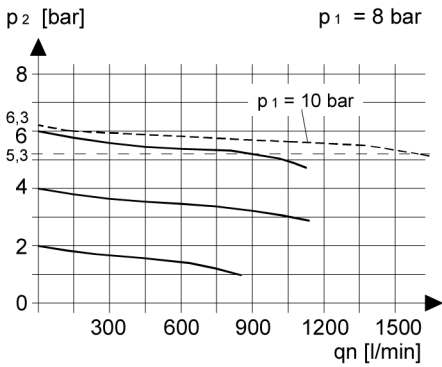

Charakterystyka ciśnienia

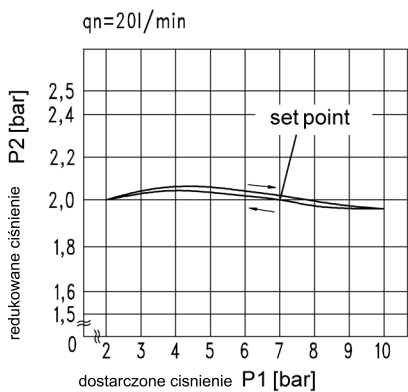

Akcesoria

